

No.	Description	Part No.
1	Volume Control	09349P-34
2	Washer, Neoprene	17165P-66
3	Knob, Volume Control	15423P-01
4	Dome, Stamped RH	40500G-01
5	Filter, Dome, Yellow	14096P-13
6	Filter, Dome, Charcoal	14096P-12
7	Earphone Assembly	10376G-20
8	Filter, Dome	25629P-08
9	Flo-Fit Gel Earseals (pr)	40243G-05
10	Headband Assy Kit	18900G-73
11	Headpad Latch Kit	18900G-72

No.	Description	Part No.
12	Headpad, Stretching(H20-10)	40501G-01
	Headpad, Stretching(H20-16)	40501G-02
13	Latch Stop Kit	18900G-66
14	Dome, Stamped LH	40499G-01
15	Boom Attachment Kit	12840G-12
16	Mic Boom Assembly	18688G-08
17	Mic Plug Cord	18744G-01
18	M-7A Microphone	09168P-33
19	Mic Protector	40062G-02
20	Comm Cord Kit (H20-10)	18028G-01
21	Comm Cord Kit (H20-16)	18028G-05
22	Clothing Clip	18900G-86

ELECTRICAL SCHEMATIC

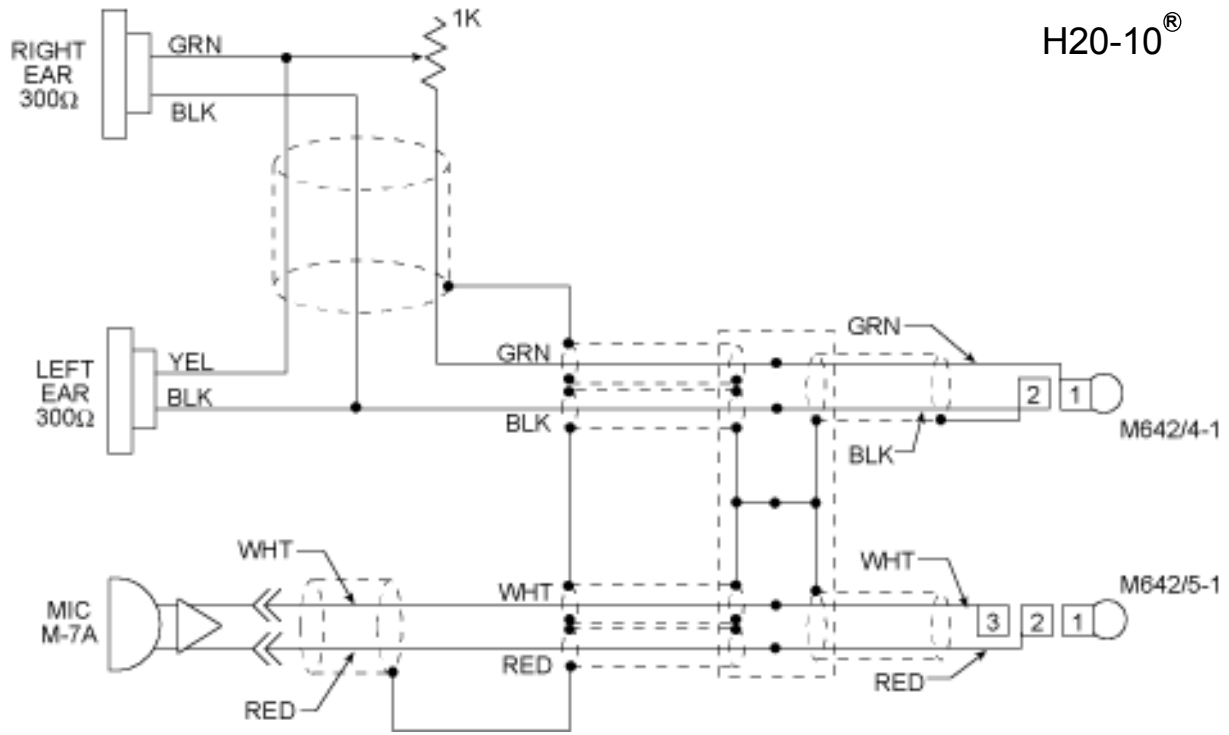

H20-16

